



M A T E R I A L S	BODY	PASSIVATED STAINLESS STEEL
	CONTACT	GOLD PLATED
	INSULATOR	PTFE
H A R D W A R E		
	NUT	WASHER



Scale 2.5:1

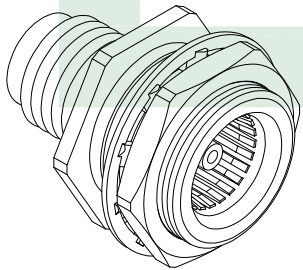
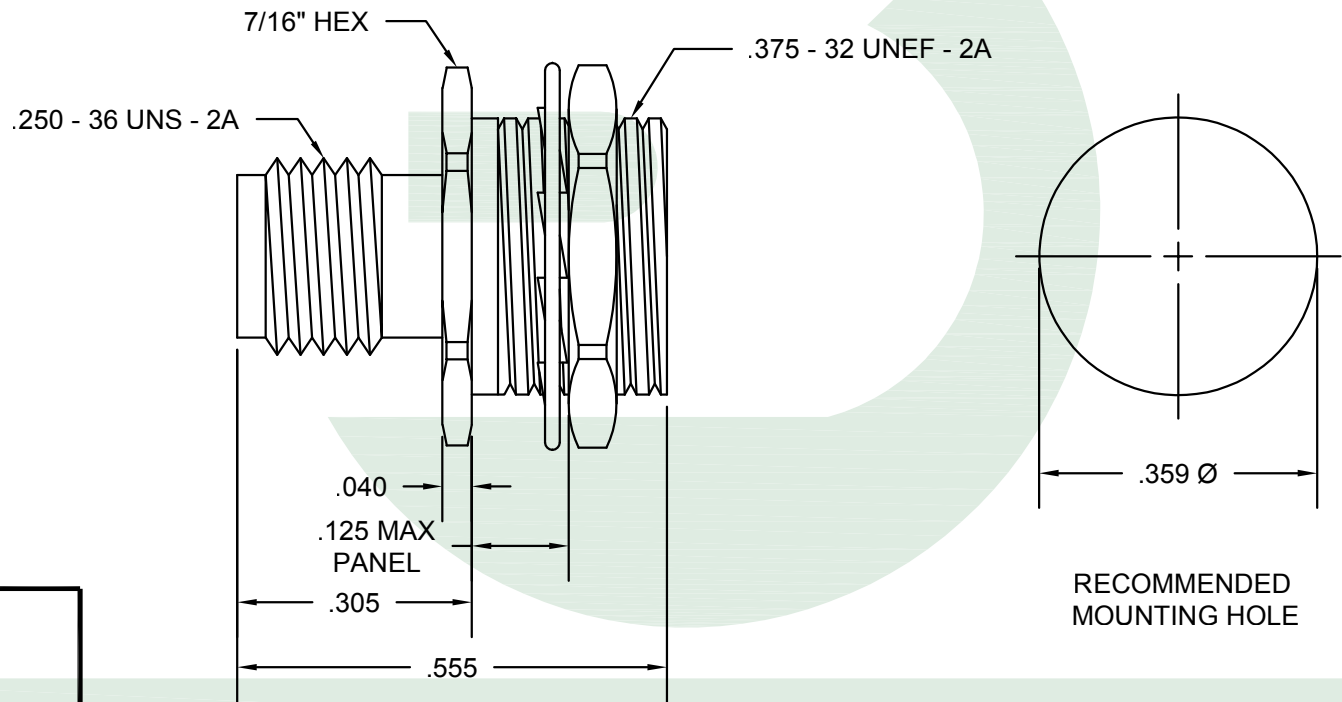

**BRACKE**  
Bracke Manufacturing, LLC



**Bracke Manufacturing, LLC**  
PO Box 12319  
Newport Beach, Ca 92658  
Phone (949)756-1600 / Fax (949) 756-1601  
sales@brackemfg.com / www.brackemfg.com

Part Number	
<b>BM50599</b>	
Produced By	Checked By
002	013

Description  
**SMA Female to BMA Jack Bulkhead Mount**  
50 Ohm [Precision Adapter, Max VSWR 1.15:1 @ 18 GHz]

Notes

- Bracke Manufacturing, LLC reserves the right to change any specifications at any time in its sole discretion without notice.
- The depiction above was produced by and is the sole property of Bracke Manufacturing, LLC and may not be copied or reproduced in any manner without Bracke's prior written consent.

©2017 Bracke Manufacturing, LLC

CAGE / NAGE	
6LOW2	
Scale	Unit
4:1	Inches
Date	Revision
4/28/2017	A-01