

MwT-17

**500 MHz-12 GHz High Linearity
Low Noise GaAs FET**

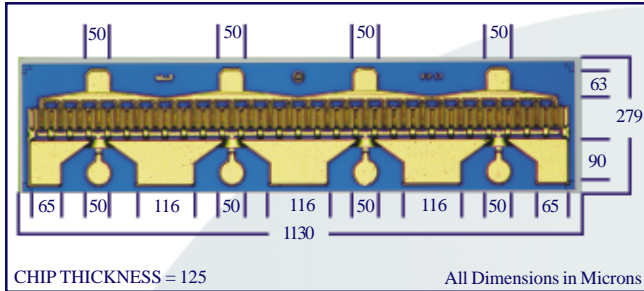

DOWNLOAD ADDITIONAL DATA WWW.MWTINC.COM



FEATURES

- 1 WATT POWER OUTPUT WITH HIGH LINEARITY
- HIGH ASSOCIATED GAIN
- 0.8 MICRON REFRACTORY METAL/GOLD GATE
- 2400 MICRON GATE WIDTH
- DIAMOND-LIKE CARBON PASSIVATION
- CHOICE OF CHIP AND ONE PACKAGE TYPE

DESCRIPTION

The MwT-17 is a GaAs MESFET device which is ideally suited to narrow-band applications such as cellular telephone, PCN, point-to-point communications links, and other wireless applications as the driver transistor for the output power amplifier. The third-order intercept performance of the MwT-17 is excellent, typically 15 dB above the 1 dB compression point. The chip is produced using MwT's reliable metal system and devices from each wafer are screened to insure reliability. All chips are passivated using MwT's patented "Diamond-Like Carbon" process for increased durability. Designers can use MwT's unique BIN selection feature to choose devices from narrow Idss ranges, insuring consistent circuit operation.

DC SPECIFICATIONS AT Ta = 25°C

SYMBOL	PARAM. & CONDITIONS	UNITS	MIN	TYP	MAX
IDSS	Saturated Drain Current Vds= 3.0 V VGS= 0.0 V	mA	240	920	
Gm	Transconductance Vds= 2.0 V VGS= 0.0 V	mS	290	380	
Vp	Pinch-off Voltage Vds= 3.0 V IDS= 16.0 mA	V		-2.5	-5.0
BVGSO	Gate-to-Source Breakdown Volt. Igs= -1.6 mA	V	-6.0	-12.0	
BVGDO	Gate-to-Drain Breakdown Volt. Igd= -1.6 mA	V	-8.0	-12.0	
Rth	Thermal Resistance MwT-17 Chip	°C/W		33	

*Overall Rth depends on case mounting.

RF SPECIFICATIONS AT Ta = 25°C

SYMBOL	PARAMETERS AND CONDITIONS	FREQ	UNITS	MIN	TYP
P1dB	Output Power at 1 dB Compression VDS= 6.0 V IDS= 420mA	12 GHz	dBm	28.5	30.0
PAE	Power Added Efficiency VDS= 6.0 V IDS= 420mA	12 GHz	%	20	30
SSG	Small Signal Gain VDS= 6.0V IDS= 420mA	12 GHz	dB	6	7.0
IDSS	Recommended IDSS Range for Optimum P1dB		mA		480-760
IP3	Intercept Point 3rd Order VDS= 6.0V IDS= 420mA	12 GHz	dBm		+45
NF	Noise Figure VDS= 6.0V IDS= 420mA	900 MHz	dB		0.8

DEVICE EQUIVALENT CIRCUIT MODEL

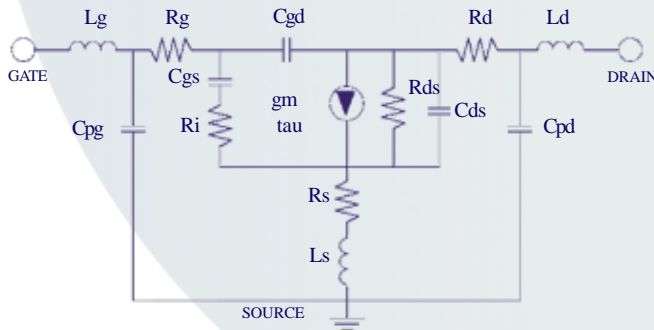

PARAMETER

VALUE

Source Resistance	Rs	0.2	Ω
Source Inductance	Ls	0.04	nH
Drain-Source Resistance	Rds	40.0	Ω
Drain-Source Capacitance	Cds	0.4	pF
Drain Resistance	Rd	0.17	Ω
Drain Pad Capacitance	Cpd	0.2	pF
Drain Inductance	Ld	0.06	nH
Gate Bond Wire Inductance	Lg	0.16	nH
Gate Pad Capacitance	Cpg	0.1	pF
Gate Resistance	Rg	0.1	Ω
Gate-Source Capacitance	Cgs	2.5	pF
Channel Resistance	Ri	1.0	Ω
Gate-Drain Capacitance	Cgd	0.25	pF
Transconductance	gm	330	mS
Transit Time	tau	1.7	psec

ORDERING INFORMATION

Chip MwT-17
Package 71 MwT-1771

NOTE:

For Package information, please see supplementary application note from our website at www.mwtinc.com. When placing order or inquiring, please specify BIN range, wafer no., if known, and screening level required.

4268 Solar Way Fremont California 94538 Phone: (510) 651-6700 Fax: (510) 651-2208

All rights reserved. MicroWave Technology, Inc. All specifications subject to change without notice.

MwT-17

500 MHz-12 GHz High Linearity
Low Noise GaAs FET



Bonding Diagram for the MwT-17 is Forthcoming

Please Refer to Factory for Information

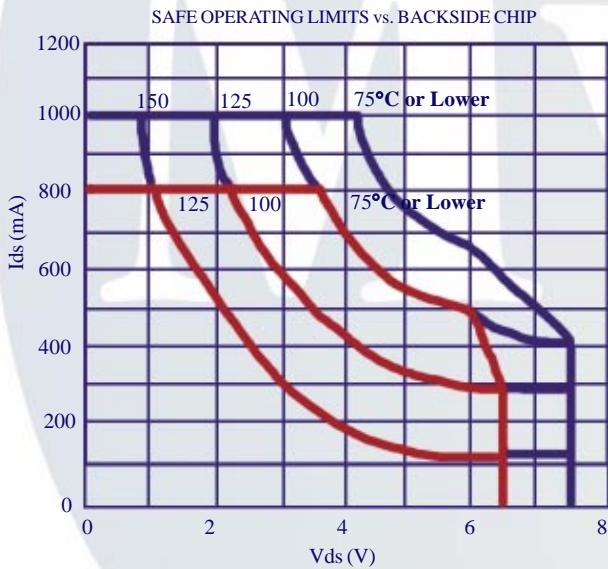

█ Absolute Maximum
 █ Continuous Maximum

MAXIMUM RATINGS AT Ta = 25°C

SYMBOL	PARAMETER	UNITS	CONT MAX ¹	ABSOLUTE MAX ²
VDS	Drain to Source Voltage	V	See Safe Operating Limits	
Tch	Channel Temperature	°C	+150	+175
Tst	Storage Temperature	°C	-65 to +150	+175
Pin	RF Input Power	mW	950	1400

NOTES: 1. Exceeding any one of these limits in continuous operation may reduce the mean-time-to-failure below the design goals.
2. Exceeding any one of these limits may cause permanent damage.

BIN SELECTION

BIN#	1	2	3	4	5	6	7	8	9	10	11	12	13	14	15	16	17	18
IDSS (mA)	240-280	280-320	320-360	360-400	400-440	440-480	480-520	520-560	560-600	600-640	640-680	680-720	720-760	760-800	800-840	840-880	880-920	920-960

BIN ACCURACY STATEMENT

When placing order or inquiring, please specify BIN range, wafer no., if known, and screening level required.